



SENSOR[®]
NETWORKS, INC

Inspection, Testing & Asset-Integrity Solutions

SensorScan[®] DHT-400

HIGH-TEMP DUAL-ELEMENT TRANSDUCER

FOR THICKNESS MEASUREMENTS
ON ROUGH OR CORRODED SURFACES

The SensorScan Model DHT-400 Ultrasonic Transducer is a general-purpose sensor for measuring the remaining wall thickness on rough metal ID and OD surfaces due to corrosion and/or erosion. The transducer can be used intermittently (50% duty cycle) over a wide temperature range from 0 to 932°F (-17.8 to 500°C) and continuously from 0 to 400°F (-17.8 to 204°C).

Typical applications include its use with common digital thickness gauges or flaw detectors on boiler/furnace tubes, pipes, tanks, vessels, structures and other safety-critical components at power plants, refineries, mid- and up-stream Oil & Gas assets, and chemical facilities.



specifications

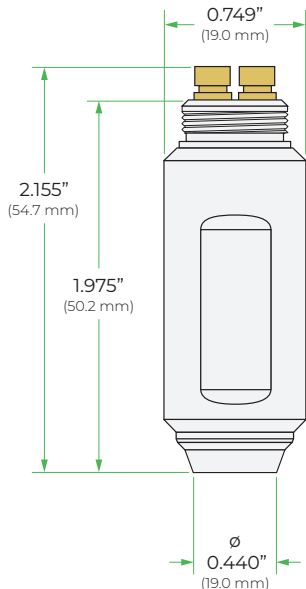

frequency	5 MHz (nominal)
delay roof angle	5 degree (10 degree included)
connector type	MD #10-32 (2x) or MCX (2x)
contact diameter	0.440" (11.2 mm)
min. and max thickness (steel)	Min.: 0.040" (1.0 mm), Max: 10" (254 mm)
continuous use temperature	400°F (204°C)
maximum contact temperature	932°F (500°C) Intermittent
duty cycle	50% at 10 seconds (max recommended)
cable options	5 ft. (1.52m) standard & armored cable
cable connector options	Lemo-00, Olympus- & Krautkramer-style gauge
compatible instruments	38DL PLUS, 37DL PLUS, 36DL PLUS DMS GO, All Flaw Detectors
DHT-400 case	Delivered in hard-shell case for field use

RF Waveform:
Backwall signal from 1" steel block

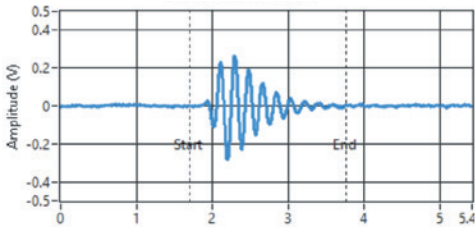

RF Waveform:
#2 FBH @ 0.5"

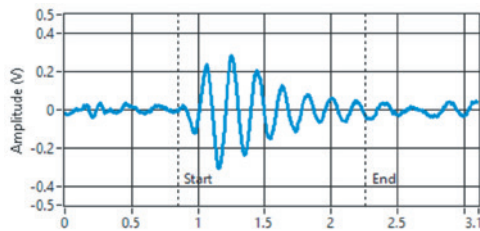

Frequency Spectrum

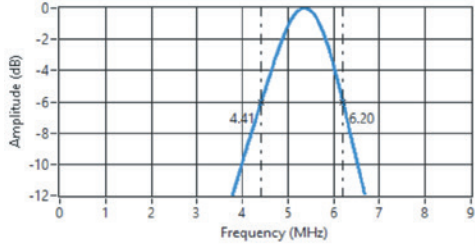

Frequency Spectrum

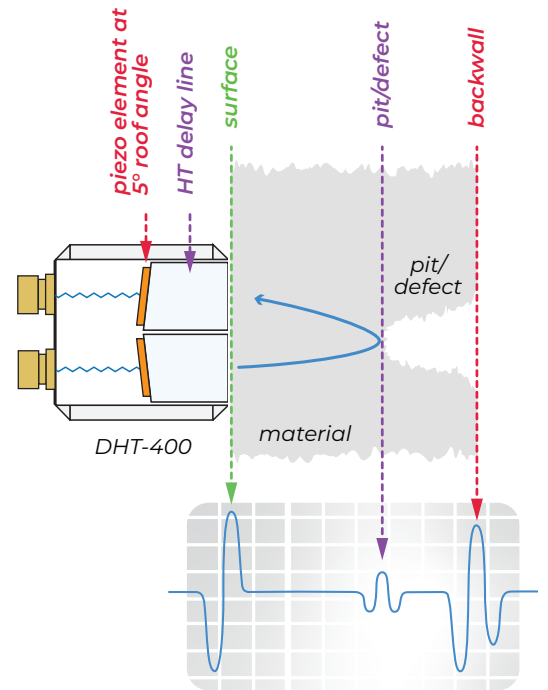
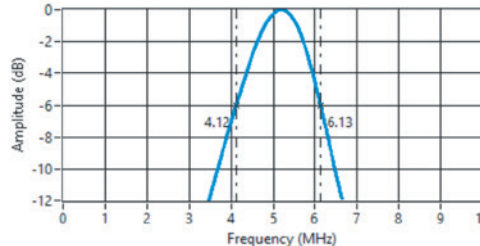

The two 5° roof angles create a pseudo-focusing effect thereby increasing the transducer's sensitivity for pit-like defects.

DAC Curve

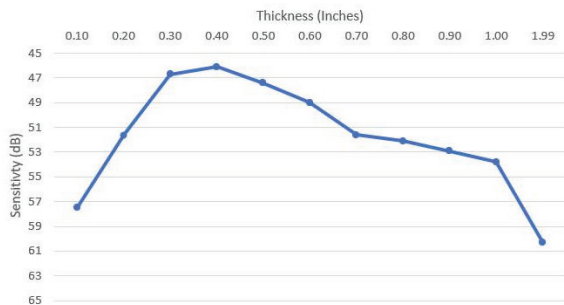

Thermal-cycle testing

400°F Heat Up at 932°F

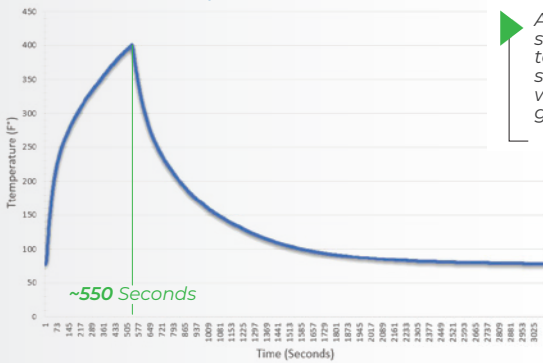

At 932°F continuous surface contact temp, it takes over 9 minutes for the sensitive solder joints within the transducer to get to 400°F.

5 Sec. Contact, 10 Sec off at 932°F

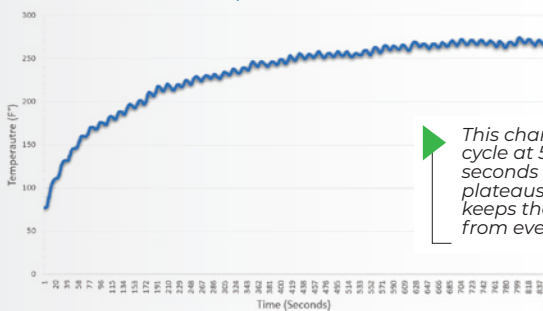

This chart shows a 33% duty cycle at 5 seconds on and 10 seconds off. The DHT-400 plateaus at ~270°F which keeps the sensitive elements from ever reaching 400°F.



Offered by Echo Ultrasonics, LLC
774 Marine Drive, Bellingham, WA 98225
www.echoultrasonics.com 360-671-9121



Ver. 1.2
©2021 Sensor Networks, Inc. All rights reserved.
Sensor Networks, Inc.® and SensorScan® are registered trademarks of SNI.
Visit www.utcatalog.com for our complete catalog of UT products.